

冲压外圈型: KH

Pressing Bush Bearing: KH

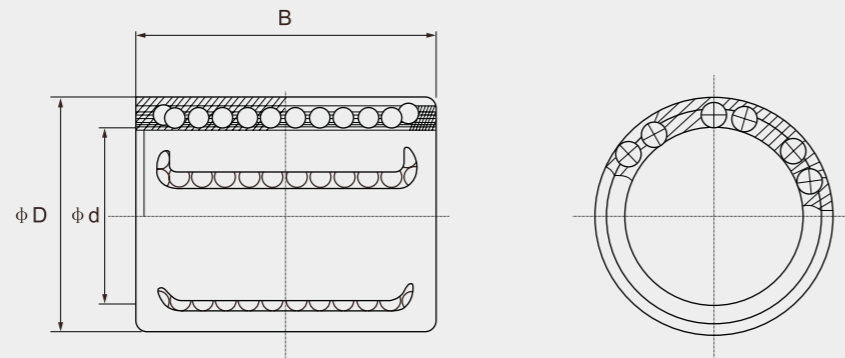

KH...



型号 Model	主要尺寸 Major dimensions (mm)			额定负荷 Basic load rating		重量 Weight (g)
	ϕd	ϕD	B	动负荷 Dynamic C N	静负荷 Static Co N	
KH0622PP	6	12	22	239	400	7
KH0824PP	8	15	24	280	435	12
KH1026PP	10	17	26	370	500	14.5
KH1228PP	12	19	28	510	620	18.5
KH1428PP	14	21	28	520	620	20.5
KH1630PP	16	24	30	620	800	27.5
KH2030PP	20	28	30	790	950	32.5
KH2540PP	25	35	40	1,670	1,990	66
KH3050PP	30	40	50	2,700	2,800	95
KH4060PP	40	52	60	4,400	4,450	182
KH5070PP	50	62	70	5,500	6,300	252

密封型
Seal type

不标	不带密封	No entry	No seals
P	单密封	P	Seal on one side
PP	双密封	PP	Seal on both sides

法兰式直线轴承 Flanged Linear Motion Ball Bearing

- SNB 法兰型直线轴承外圆上有一个垂直的安装平台，故安装时不需轴承座，从而大大地降低了成本。
- 法兰型直线轴承具有足够的刚性，它能承受标准型直线轴承所能承受的同等负荷。法兰盘经过精密加工，与轴承外径的垂直精度很高，具有良好的互换性，维修更换十分方便。
- The SNB flanged linear motion ball bearing is equipped with a vertical fixing plat(flange) perpendicular mounting surface as part of the outer casing. Therefore, it does not require a housing thus providing high cost efficiency, no housing required, which low cost much.

- Flanged linear motion ball bearings have sufficient rigidity to support equivalent loads of standard ball bushings. Incorporated in this design is a finely machined flange and outer diameter with high precision perpendicularity, and excellent flange interchangeability to simplify replacement.

结构和优点 Structure and Features

- 这种结构提供了一种不同的安装方法，它不需要轴承支架，也不需要轴承压入到轴承座中。
- SNB 法兰型直线轴承有标准型的，也有加长型的，有法兰盘在端部的，也有法兰盘在中间的，法兰盘在中间的可以更好地承受力矩负荷。
- 不需要单独的轴承座
- 结构紧凑
- 足够的刚性
- 更换时仍能保持高精度

- This design enables various mounting methods other than conventional pillow blocks and press fit ball bushings.
- SNB flanged linear motion ball bearings include single retainer and mounted flange as well as double retainer and end mount and certain red mounted flange type with excellent moment load capability.
- No housing required
- Compact design
- Excellent rigidity
- High accuracy upon replacement